

文件编号 File No: LW2460-200-136ZY-A

LW2460 动臂塔式起重机

LW2460 Luffing Tower Crane

产品样本
Stylebook

For reference only!

中联重科股份有限公司

风电塔机外形图 Outline drawing of the luffing tower crane

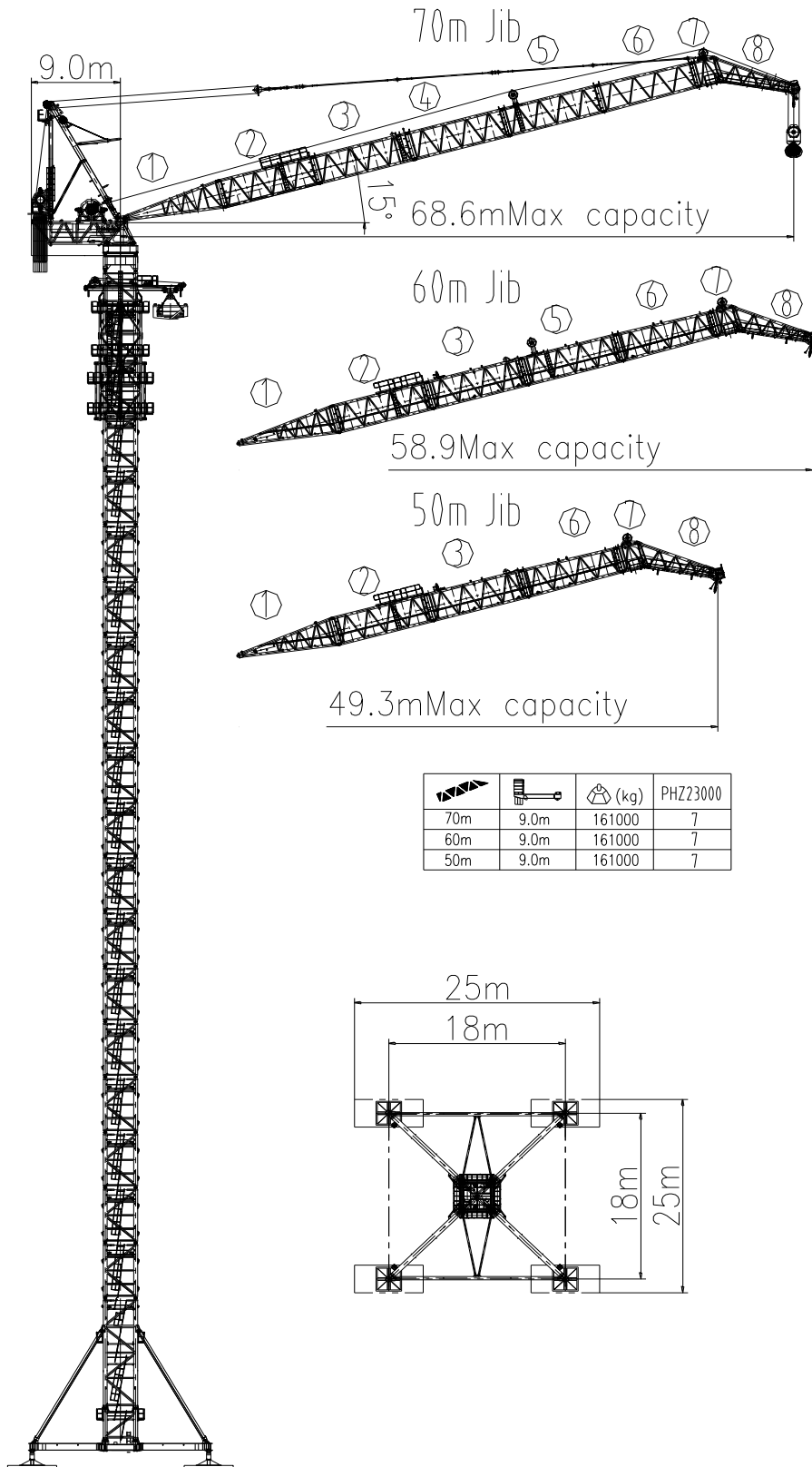

LW2460-200

整机性能 Overall performance

Working Level of Tower Crane		A4									
Working Level of Mechanism		Hoisting Mechanism			M4						
		Slewing Mechanism			M5						
		Luffing Mechanism			M4						
Maximum lifting torque (t . m)		2460									
Maximum hoisting capacity of 198 meters lifting height (t)		160									
Maximum hoisting capacity of 180 meters hoisting height (t)		180									
Maximum hoisting capacity of 160 meters hoisting height (t)		200									
Maximum hoisting capacity of 150 meters hoisting height (t)		200									
Min / Max radius (m)		8.0/68.6									
Capacity in maximum radius (t) (198m hoisting height)		1.0 (6 Falls)									
Capacity in maximum radius (t) (180m hoisting height)		3.3 (6 Falls)									
Capacity in maximum radius (t) (160m hoisting height)		15.4 (6 Falls)									
Capacity in maximum radius (t) (150m hoisting height)		30.3 (6 Falls)									
Maximum independent hoisting height (m)		198									
起升机构 Hoisting mechanism H315FC335-1360D	Hoisting Speed	Falls	2			4			6		
		Hoisting speed (m/min)	25.5	51	66	12.8	25.5	33	7.5	15	19
		Capacity in the max capacity of 200t	66	33	16.5	133	66	33	200	100	50
	Hoisting Speed	Falls	2			4			6		
		Hoisting speed (m/min)	25.5	51	66	12.8	25.5	33	8.5	17	22
		Capacity in the max capacity of 180t	60	30	15	120	60	30	180	90	45
	Hoisting Speed	Falls	2			4			6		
		Hoisting speed (m/min)	25.5	51	66	12.8	25.5	33	8.5	17	22
		Capacity in the max capacity of 160t	53	27	13.5	106	53	27	160	80	40
	Rope capacity(m)		1360								

LW2460-200









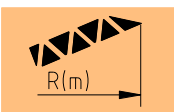

	Brake torque(N. m)	5200		
	Wire rope model	GS-k34-Φ42-1960		
Hoisting mechanism in introduction system H55FC95-290	Falls	2		
	Speed (m/min)	15		
	Lifting Weight (t)	16		
	Rope capacity(m)	290		
	Brake torque (N. m)	900		
	Wire rope type	GS-k34-Φ20-1960		
	Luffing mechanism L160FC270	Luffing time (min)	4	
Luffing mechanism in introduction system EYJ1000/10	Luffing time (min)	1.8		
Slewing mechanism S185CA-350.275C C20/13A	Speed (r/min)	0.5		
Jacking mechanism	Speed (m/min)	1		
	Working pressure (MPa)	31.5		
Total power(kW)		512(exclude jack mechanism, introduction system)		
Counter weight	Counter length (m)	70	60	50
	Weight (t)	161	161	161
Allowable wind speed at top of tower crane (m/s)		Climbing condition		14
		Working condition		20
		Non Working condition		35.8
Working power supply		380V/50Hz		
Working temperature		-20℃~+40℃		

起重特性 Load diagrams

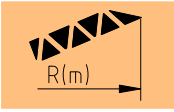





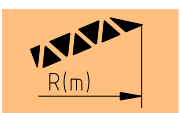

70m 臂长性能 (198 米起升高度)

Performance of 70 meters Jib (198 meters hoisting height)



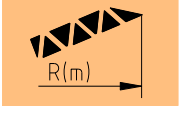



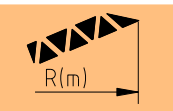

	倍率 falls	Max Capacity m/t	Radius (m)	13	15	17.5	20	22.5	25	27.5	30	32.5	35	37.5	40
70		9.4~12.5/160	Capacity (t)	158.8	138.5	112.2	95.8	80.7	68.5	58.5	52.1	45.3	39.0	33.5	29.0
		9.4~17.8/108	Capacity (t)	108	108	108	99.4	84.3	72.0	62.0	55.6	48.8	42.5	36.9	32.1
		9.4~31.4/54	Capacity (t)	54.0	54.0	54.0	54.0	54.0	54.0	54.0	54.0	54.0	52.3	45.9	40.4
	倍率 falls	Max Capacity m/t	Radius (m)	42.5	45	47.5	50	52.5	55	57.5	60	62.5	65	67.5	68.6
70		9.4~12.5/160	Capacity (t)	24.4	20.7	17.4	15.2	12.5	10.1	8.0	6.1	4.3	2.8	1.5	1.0
		9.4~17.8/108	Capacity (t)	27.8	24.1	20.7	18.5	15.8	13.3	11.1	9.1	7.3	5.7	4.2	3.7
		9.4~31.4/54	Capacity (t)	31.2	27.4	24.0	21.7	19.0	16.5	14.2	12.2	10.3	8.6	7.0	6.3

70m 臂长性能 (180 米起升高度)



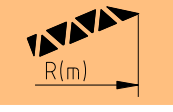



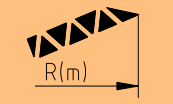

Performance of 70 meters Jib (180 meters hoisting height)

	倍率 falls	Max Capacity m/t	Radius (m)	13	15	17.5	20	22.5	25	27.5	30	32.5	35	37.5	40
70		9.4~13.0/180	Capacity (t)	180.0	166.5	135.5	113.4	97.4	83.1	71.3	61.6	53.3	46.3	40.8	35.5
		9.4~18.9/120	Capacity (t)	120	120	120	116.3	100.7	86.3	74.6	64.8	56.5	49.5	43.9	38.6
		9.4~31.3/60	Capacity (t)	60.0	60.0	60.0	60.0	60.0	60.0	60.0	60.0	60.0	59.7	52.7	47.1
	倍率 falls	Max Capacity m/t	Radius (m)	42.5	45	47.5	50	52.5	55	57.5	60	62.5	65	67.5	68.6
70		9.4~13.0/180	Capacity (t)	30.8	26.6	22.9	20.0	17.0	14.3	11.8	9.6	7.5	5.7	4.1	3.3
		9.4~18.9/120	Capacity (t)	33.9	29.7	25.9	23.0	19.9	17.2	14.6	12.3	10.2	8.2	6.5	5.7
		9.4~31.3/60	Capacity (t)	36.9	32.7	28.9	25.9	22.8	20.0	17.4	15.0	12.8	10.8	8.5	6.4



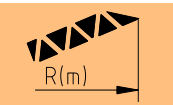



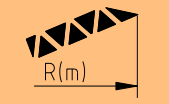

60m performance characteristics (Max capacity:180t, Max hoisting height: 170m)

	Falls	Max Capacity m/t ²	13	15	17.5	20	22.5	25	27.5	30	32.5	35	37.5	40
60		8.7~13.7/180	180	171.6	139.3	115.2	97.9	84.1	72.9	63.6	55.8	49.1	43.3	38.4
		8.7~18.8/120	120	120	120	118.3	102.3	87.2	75.9	66.6	58.8	52.1	46.3	41.3
		8.7~32.9/60	60	60	60	60	60	60	60	60	60	60	55.0	49.2
	Falls	Max Capacity m/t	42.5	45	47.5	50	52.5	55	57.5	58.9				
60		8.7~13.7/180	34.2	30.5	27.2	24.3	21.5	18.8	16.5	15.2				
		8.7~18.8/120	37.0	33.3	29.9	27.0	24.1	21.3	18.9	17.5				
		8.7~32.9/60	39.9	36.1	32.7	29.6	26.7	23.3	21.3	19.8				



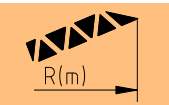



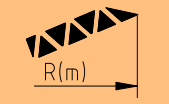

50m performance characteristics (Max capacity:180t, Max hoisting height: 160m)

	Falls	Max Capacity m/t ²	13	15	17.5	20	22.5	25	27.5	30	32.5	35	37.5	40
50		8.0~13.1/180	180	172.1	142.3	120.1	102.6	88.6	77.2	67.7	59.8	52.9	47.0	41.9
		8.0~19.7/120	120	120	120	119.8	105.5	91.4	80.0	70.5	62.5	55.7	49.7	44.5
		8.0~34.2/60	60	60	60	60	60	60	60	60	60	60	58.4	52.4
	Falls	Max Capacity m/t	42.5	45	47.5	49.3								
50		8.0~13.1/180	37.4	33.4	29.9	27.5								
		8.0~19.7/120	40.0	35.9	32.2	29.8								
		8.0~34.2/60	42.5	38.4	34.6	32.0								

60m performance characteristics (Max capacity:200t, Max hoisting height: 160m)

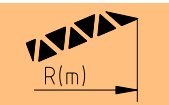
	Falls	Max Capacity m/t	13	15	17.5	20	22.5	25	27.5	30	32.5	35	37.5	40	42.5
60		8.7~12.8/200	198.5	177.1	145.4	121.8	103.5	89.0	77.2	67.4	59.1	52.0	45.9	40.6	35.9
		8.7~18.8/133	133	133	133	124.7	106.5	92.0	80.1	70.3	62.0	54.9	48.7	43.4	38.6
		8.7~32.0/66.0	66.0	66.0	66.0	66.0	66.0	66.0	66.0	66.0	66.0	64.7	57.7	51.6	46.1
	Falls	Max Capacity m/t	45	47.5	50	52.5	55	57.5	59.0						
60		8.7~12.8/200	31.7	28.0	24.7	21.8	19.1	16.7	15.4						
		8.7~18.8/133	34.4	30.7	27.3	24.3	21.5	19.0	17.6						
		8.7~32.0/66.0	37.1	33.3	29.9	26.8	24.0	21.3	19.8						

50m performance characteristics (Max capacity:200t, Max hoisting height: 150m)

	Falls	Max Capacity m/t	13	15	17.5	20	22.5	25	27.5	30	32.5	35	37.5	40	42.5
50		8.0~13.1/200	198.8	181.9	150.1	126.5	108.2	93.7	81.9	72.0	63.7	56.7	50.5	45.2	40.5
		8.0~18.9/133	133.0	133	133	129.3	111.0	96.4	84.6	74.7	66.4	59.3	53.1	47.7	43.0
		8.0~33.5/66.0	66.0	66	66	66	66	66	66	66	66	66	61.9	55.7	50.2
	Falls	Max Capacity m/t	45	47.5	49.3										
50		8.0~13.1/200	36.4	32.7	30.3										
		8.0~18.9/133	38.7	34.9	32.4										
		8.0~33.5/66.0	41.1	37.2	34.5										

Caution: The above hoisting performance characteristic data is calculated according to the height of the tower crane boom root hinge point. When the height of the crane boom root hinge point is less than the height of the independently installed boom root hinge point, the hoisting capacity in the hoisting performance characteristic table must be reduced. The calculation method is: Hoisting capacity of calculated height=Hoisting capacity in performance table + Weight of wire rope per meter× (calculation height-H1) ×falls.(height unit : m, weight: t, the calculated height shall be the actual tower height).

CAUTION

When hoisting wind power equipment, the load rate shall not exceed 100%.

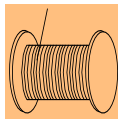
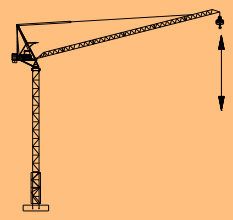

The maximum hoisting height of the standard tower crane can reach 180m. If the maximum hoisting height needs to reach 198m, three reinforcing joints need to be added, and the hoisting wire rope with a length of 1350m and the lifting wire rope of inlet system with a length of 290m need to be replaced at the same time.

传动机构 Transmission mechanisms

起升 Hoisting	配置 Configuration	Falls		bbb			bb			b			kW	
		Hoisting gear		III	IV	V	III	IV	V	III	IV	V		
	H315FC335-1360D	Max Capacity of 200t	m/min	25.5	51	66	12.8	25.5	33	7.5	15	19	315	1360m ϕ (7 layers)
			t	66	33	16.5	133	66	33	200	100	50		
		Max Capacity of 180t	m/min	25.5	51	66	12.8	25.5	33	8.5	17	22		
			t	60	30	15	120	60	30	180	90	45		
		Max Capacity of 160t	m/min	25.5	51	66	12.8	25.5	33	8.5	17	22		
			t	53	27	13.5	106	53	27	160	80	40		
回转 Slewing	S185CA-350.275CC20/13A(M) S185CA-350.275CC20/13A-120		r/min	0 ~ 0.5									2 \times 18.5	ϕ 超出咨询我们 Consult us if overtop
变幅 Luffing	L160FC280		min	4.0 (15 $^{\circ}$ ~86 $^{\circ}$)									160	

LW2460-200

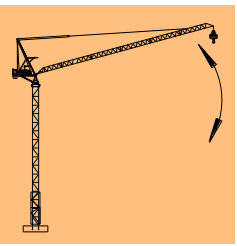
ZOOMLION
LW2460-200-136ZY-A

								
	380V(±10%)50Hz				512 (kW)			

Foundation requirements

Stress of underframe outrigger

Luffing crane	Jib	Hoisting height (m)	Working condition	RA (kN)	RB (kN)	RC (kN)	RD (kN)	地耐力 (Mpa)
LW2460-160	70m	198	Working condition	2430	3887	2430	972	0.185
			No-working condition	1964	3654	1964	274	0.174
LW2460-180	70m	180	Working condition	2365	3844	2365	885	0.183
			No-working condition	1842	3299	1842	386	0.157
LW2460-200	60m	160	Working condition	2430	3887	2430	972	0.185
			No-working condition	1964	3605	1964	323	0.172

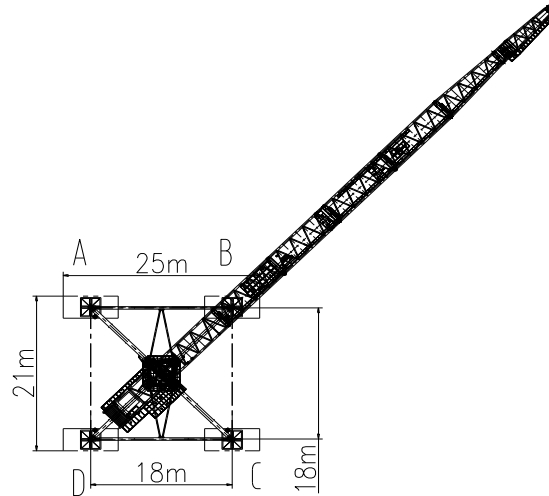

The ground endurance of the area where the cushion block is placed shall not be less than 0.2 Mpa.

LW2460-200

ZOOMLION

运输单元 Transport unit

序号 No.	部件 Parts	示意图 Sketch Map	L(m)	B(m)	H(m)	单重(t) Unit Weight	数量 Num
1	臂节I JobI		10.5	3.1	3.2	6.4	1
2	臂节II(含拉杆) JobII (Include Luffing tie plate)		10.3	3.1	3.2	5.3	1
3	臂节III(含拉杆) JobIII (Include Luffing tie plate)		10.3	3.1	3.2	5.5	1
4	臂节IV(含拉杆) JobIV (Include Luffing tie plate)		10.3	3.1	3.2	5.2	1

LW2460-200

序号 No.	部件 Parts	示意图 Sketch Map	L(m)	B(m)	H(m)	单重(t) Unit Weight	数量 Num
5	臂节V(含拉杆) JobV (Include Luffing tie plate)		10.3	3.1	3.2	5.2	1
6	臂节VI(含拉杆) JobVI (Include Luffing tie plate)		10.3	3.1	3.2	5.2	1
7	臂节VII(含拉杆) JobVII (Include Luffing tie plate)		2.6	2.0	3.2	2.3	1

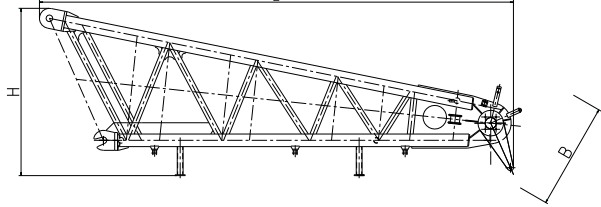
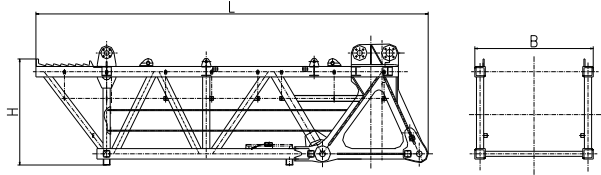
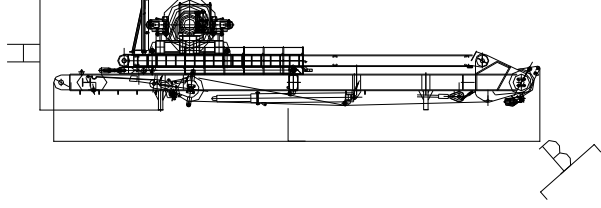
序号 No.	部件 Parts	示意图 Sketch Map	L(m)	B(m)	H(m)	单重(t) Unit Weight	数量 Num
8	臂节VIII JobVIII		9.3	2.1	3.3	5.4	1
9	平衡臂结构 Counter Weight Job		10.5	3.2	2.8	23.5	1
10	A 字架 (含变幅机构、变幅钢丝绳) A-frame (include Luffing mechanism & Luffing rope)		14.8	3.2	2.2	37.2	1

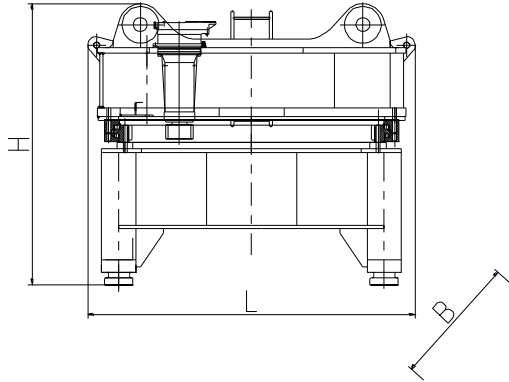
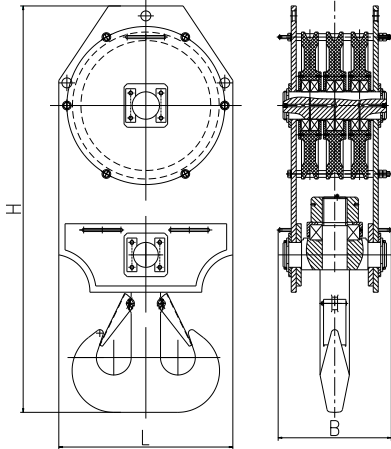
序号 No.	部件 Parts	示意图 Sketch Map	L(m)	B(m)	H(m)	单重(t) Unit Weight	数量 Num
11	回转总成 (不含回转电机) Slewing assembly (exclude slewing motor)		3.7	3.6	3.3	32.5	1
12	吊钩组 Hook		1.4	0.9	3.3	5.0	1

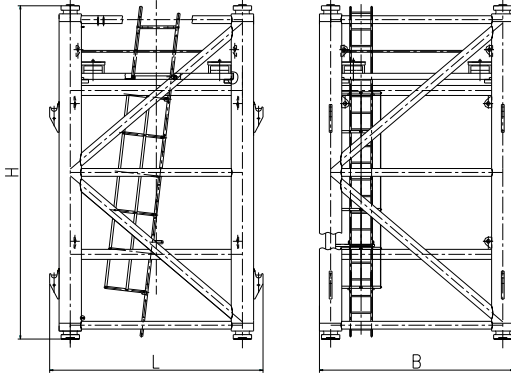
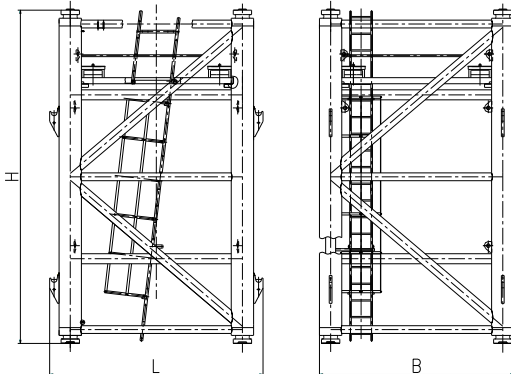
序号 No.	部件 Parts	示意图 Sketch Map	L(m)	B(m)	H(m)	单重(t) Unit Weight	数量 Num
13	标准节 Tower section		3.8	3.5	6.0	13.3	4
14	加强节 Reinforced Tower section		3.8	3.5	6.0	16.5	11

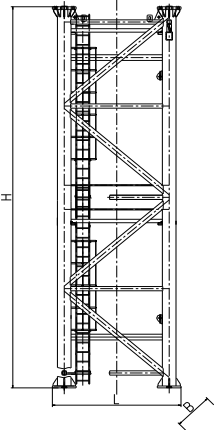
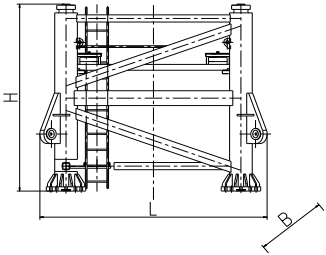
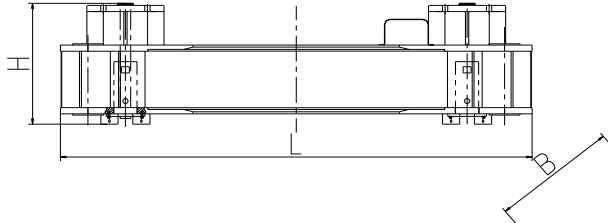
序号 No.	部件 Parts	示意图 Sketch Map	L(m)	B(m)	H(m)	单重(t) Unit Weight	数量 Num
15	基础节I (底架) Base section I (Chassis)		3.8	3.8	12.0	27.9	2
16	基础节II (底架) Base section II (Chassis)		4.0	4.0	3.52	16.3	2
17	底架基础座 (底架) Base seat (Chassis)		4.3	4.3	1.2	8.2	2

LW2460-200

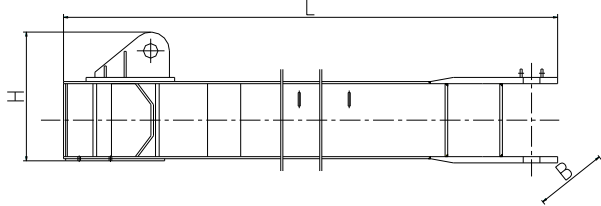
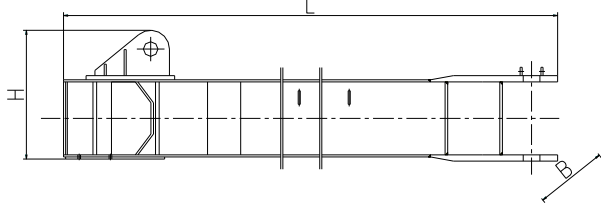
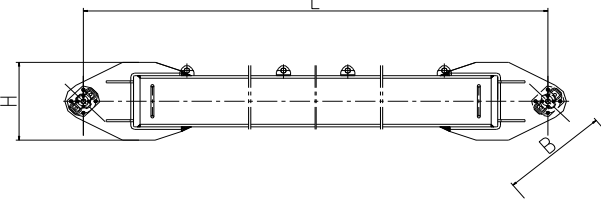
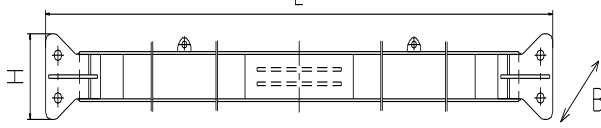
序号 No.	部件 Parts	示意图 Sketch Map	L(m)	B(m)	H(m)	单重(t) Unit Weight	数量 Num
18	大梁 A (底架) Beam A (Chassis)		10.6	0.5	1.2	4.6	4
19	大梁 B (底架) Beam B (Chassis)		10.6	0.5	1.2	4.6	4
20	斜撑杆 (底架) Diagonal brace (Chassis)		16.3	1.3	0.7	6.7	8
21	长拉杆 (底架) Long tie rod (Chassis)		16.9	0.5	0.6	2.6	2

LW2460-200

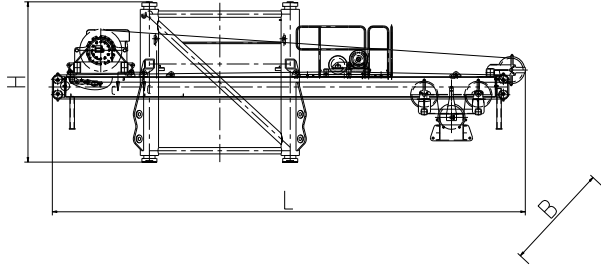
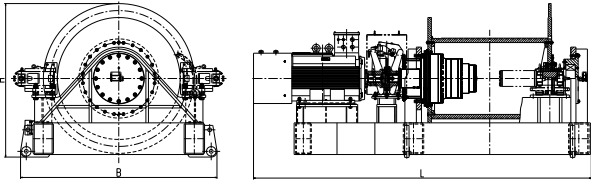
序号 No.	部件 Parts	示意图 Sketch Map	L(m)	B(m)	H(m)	单重(t) Unit Weight	数量 Num
22	过渡节及引进系统(含副起升、引进变幅机构及电控柜等) Transition section and introduction system (include auxiliary hoisting mechanism、luffing mechanism of introduction system and cabinet)		10.4	2.4	3.5	17.4	1
23	起升机构 (含 1320m 钢丝绳) Hoisting mechanism (include 1130m rope)		5.3	3.1	2.4	30.7	1

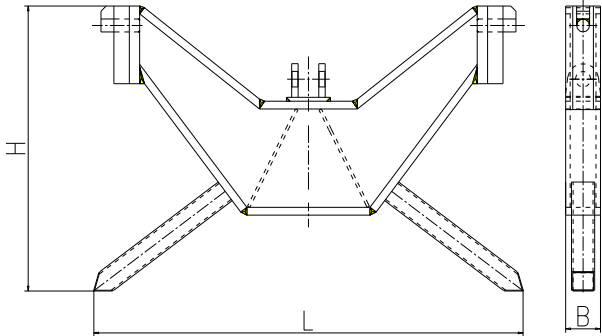
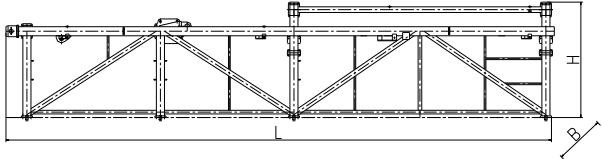
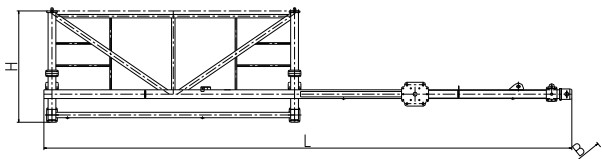
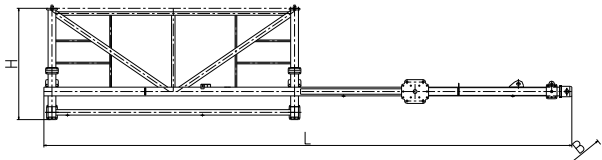
序号 No.	部件 Parts	示意图 Sketch Map	L(m)	B(m)	H(m)	单重(t) Unit Weight	数量 Num
24	顶升横梁 Jack beam		3.3	0.27	2.2	2.5	2
25	爬升架结构 L1 Structure of climbing frame L1		13.1	2.2	2.7	6.1	1
26	爬升架结构L2 Structure of climbing frame L2		13.1	2.2	2.7	5.0	1
27	爬升架结构L3 Structure of climbing frame L3		13.1	2.2	2.7	5.0	1

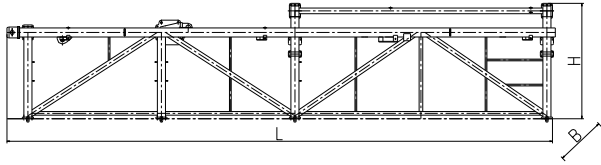
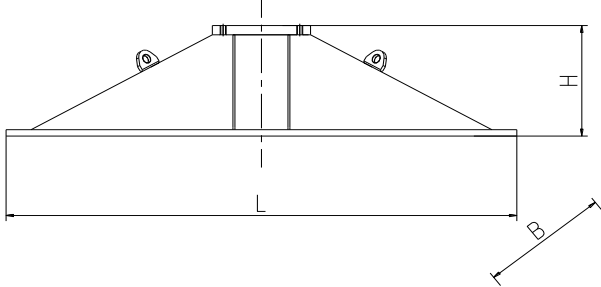
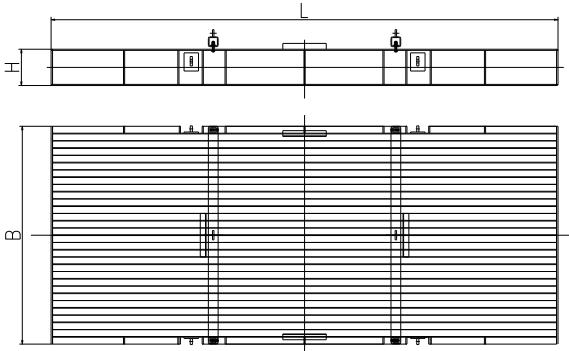
序号 No.	部件 Parts	示意图 Sketch Map	L(m)	B(m)	H(m)	单重(t) Unit Weight	数量 Num
28	爬升架结构L4 Structure of climbing frame L4		13.1	2.2	2.7	6.1	1
29	支腿座 Outrigger seat		3.6	2.6	0.6	4.2	8
30	垫块 Cushion block		8.0	5.0	0.4	21.6	8

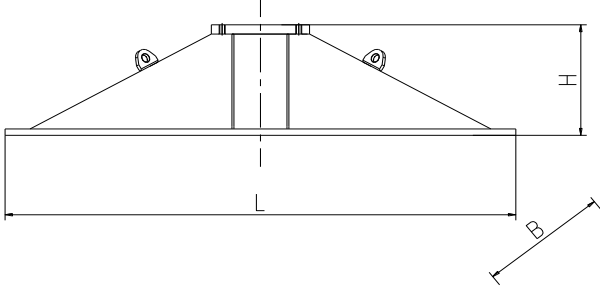
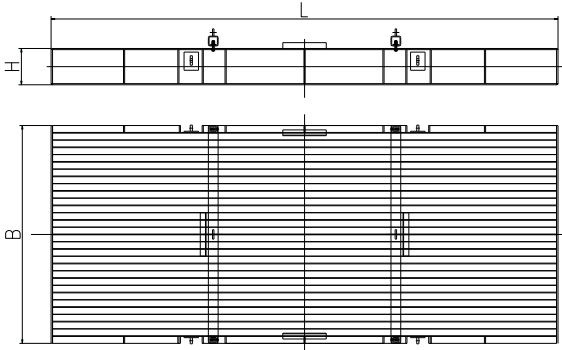
序号 No.	部件 Parts	示意图 Sketch Map	L(m)	B(m)	H(m)	单重(t) Unit Weight	数量 Num
31	支腿座 Outrigger seat		2.6	2.6	0.6	3.1	8
32	垫块 Cushion block		7.0	3.0	0.5	12.7	8

备注：项 29 和项 30 组合使用，项 31 和项 32 组合使用，两种组合根据客户实际需求进行配置。

Attention : combination of No.29 and No.30, combination of No.31 and No.31. The two combination methods are configured according to the actual needs of customers.

LW2460-200